

Install Guide for the 'Kinman' **K5 NoSoldering Harness** for Stratocasters
with specially made pots, guaranteed to maximize sonic performance.
5th April '09. Rev-2 © Chris Kinman

CAUTION: Avoid using Lead solder on Lead Free products bearing this symbol



NOTE-1: Read this completely first before beginning the project.

Note-2: The **lower pot (1)** is a Tone control for bridge pickup.

Note-3: The **middle pot (2)** is a Tone control for middle and neck pickups.

Note-4: The little slide switch on the circuit board selects the tone capacitor. Left is the HD (high definition) default setting.

Note-5: The **volume pot** has a bypass filter fitted.

Note-6: The knobs should be an easy slide fit on the Pot shafts. Open the split shaft with extreme care only if the knob is loose. If excessive force is used one half of the split shaft will break off. Also If the knob fits too tightly it will damage the pot when pulling the knob off.

Note-7. Advanced feature: Occasionally a pot or control becomes noisy or fails in use so as of 15-August-06 the Volume pot and the K9 control are 'user replaceable' without soldering. Both controls connect to the circuit using miniature plugs and sockets. Before re-assembling the guitar make sure all plugs are engaged in their sockets correctly. The White wire of the plug attached to the volume pot should be away from the pickguard.

Tools needed:

- Smallish/Medium X head screwdriver to remove and replace the pickguard mounting screws.
- Small blade screwdriver to tighten the terminal block connections.
- Razor blade or other small sharp blade to cut plastic insulation on Black ground wire. If you have cloth covered wires you don't need to cut it, just push it back to expose bare wire. (see #2)
- **USA Models:** 1/2" (or 13mm) tube spanner (or nut driver) to tighten the pots and jack socket.
- **Non USA models:** In addition to above you will need an 11mm tube spanner (or other nut driver) to remove the original pots. The pot holes in the pickguard may have to be enlarged from 5/16" (8mm) to 3/8" (9.5mm) for the Kinman pots by using a 9mm (approximately) diameter round file or tapered reamer;

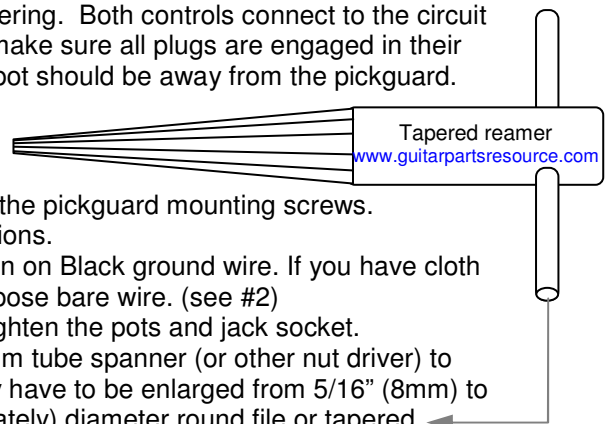

CAUTION: do not drill as it is dangerous to enlarge existing holes in a pickguard using a power drill because the drill bit will bite into the plastic and spin the pickguard causing personal injury.

Removing existing electrics

- 1) Remove the strings and then the pickguard. Place the pickguard upside down adjacent to the guitar right beside it, close enough so the output socket cable does not pull on it's connections.
- 2) Cut or break the ground wire(s) (coming from the spring claw at the rear of the guitar -and/or- from the central ground point, as the case may be) away from the casing of the volume pot by working the wire(s) around and around at the solder point until it breaks. Then cut and strip or push the insulation back about 1/4" (6mm) so it or they are ready to insert into one of the ports of the screw terminal block mounted on the cover of the NEW volume pot.
- 3) **DO NOT TAMPER** with any screw and associated solder tab that are attached to the floor or wall of any cavity. These provide a 'ground' for the conductive coating (Shielding) that is applied to the cavities and doing so will render the Shielding ineffective. If this happens the noise level from wiring will be excessive, and is difficult to fix (this is not any fault of the pickups).
- 4) Remove the Output socket from the recessed steel plate. Cut or break the output socket off the end of it's two wires by working the wires around and around at the solder points until they break.
- 5) NOTE: Try to keep the original wiring harness in tact as much as possible for possible resale.
- 6) De-mount the original pickups and controls from the pickguard and withdraw the wiring harness complete. The pickguard and guitar should now have no remaining connections to the original pickup or controls. You should now be ready for the Kinman install.

Installing the new system

- 7) Unpack and remove the replacement pickups and wiring harness from the Red plastic shipping plate. Do not disconnect the pots and also avoid disconnecting the pickups too if at all possible. Insert the special Kinman mounting screws through the pickguard and fit the Red silicone rubber tubes over them, these will hold the screws in place. Take care to arrange things to avoid tugging on wires and mount the pickup one at a time to the pickguard with **exactly the same orientation as received on the shipping plate.**
- 8) Then fit all the controls into the holes and spaces in the pickguard left by the original parts, also mount the output socket on it's recessed holder.

NOTE: The Star washer should **not** be fitted on the outside underneath the nut, but only on the inside between the recessed plate and the jack socket (in a similar fashion to the pots, shown below).

- **Make sure** the socket is tightened in the position where the *hot* leaf-spring terminal is centred on the recessed jack holder, otherwise it might contact the wall of the cavity and cause a partial short via the wood or shielding resulting is BAD sound. Also being off-centre can make the plug difficult to insert.
 - On some copy guitars it may be necessary to enlarge the cavity to avoid the short mentioned above.
 - If the pot holes are too small see *Tools needed >Non USA models* at top of page.
- 9) Check the pot bushings to ensure there are at least 2 thread ridges exposed above the pickguard. If too little thread form is available for the nut it is advisable to remove one Star washer from the pot bushing to allow sufficient grip by the fixing nut. But be aware that excessively exposed thread-form results in the skirt of the knobs being too far from the pickguard. Expect a gap between knob and pickguard of about 2mm.

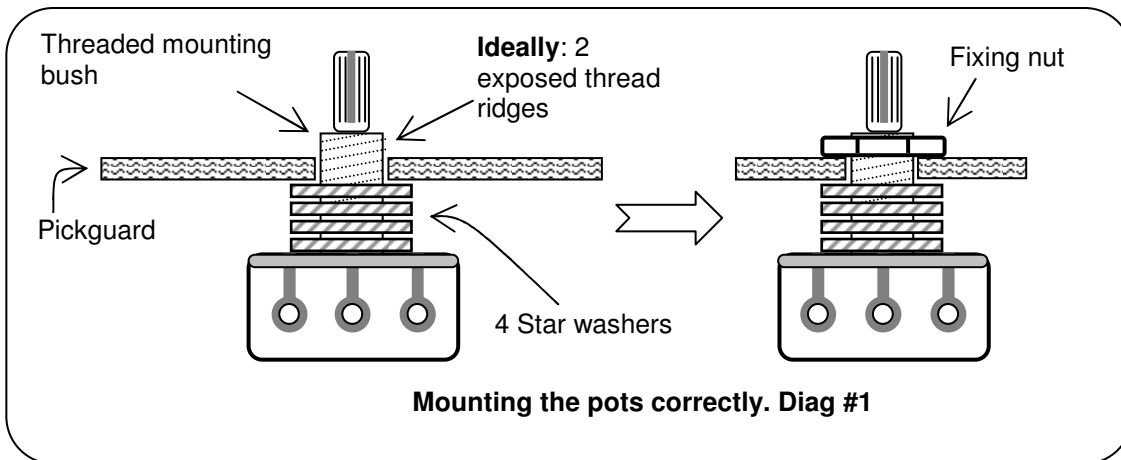

- 10) Lightly tighten the pot nuts, then adjust the rotational position of the pots and tighten the nuts firmly so the terminal plates are in line. See diagram #2. If they poke out they might cause a short circuit by contacting any shielding on the cavity wall. Tighten firmly with a 1/2" (13mm) tube spanner or spanner (do not tighten excessively).

Aligning the pots. Diag #2

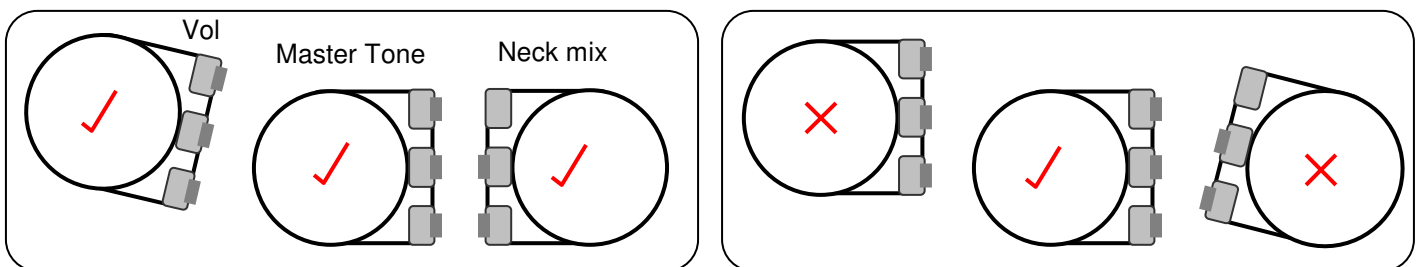

- 11) Mount the recessed jack plate and thread the cable through the connecting tunnel into the main control cavity and screw the jack holder to the guitar. The two plugs on the cable should be piggy backed, one inside the back of the other, as depicted in the diagram below. This arrangement makes it easier to feed through the connecting tunnel.

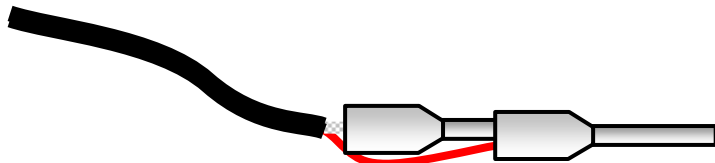

Piggy back one of the output plug into the back of the other, like this.



DO NOT TAMPER with these types of tabs fixed to wood as the shielding will be permanently damaged.



- 12) Undo the 3 screws to open the terminal ports and insert the two output Plugs and ground wire(s) into their respective screw terminals as shown in the diagram below. The Red wire is plugged into the (left) terminal furthest away from the switch. The Shield is plugged into the middle terminal and the string grounding wire/s (from the spring claw at the back of the guitar –and/or- the central ground point, as the case may be) into the remaining terminal (right). Tighten the screws firmly but not too tightly.

NOTES: I do not advocate Star grounding as a necessity; in fact it can cause headaches. With that in mind all shielding and ground wires (usually Black) should be somehow connected (either directly or indirectly) to the right hand port of the Connector block. This included the control cavity shielding (if present), output cavity shielding (if present), and the strings - direct from the bridge as in the case of hardtails or via the spring claw on vibrato models. Since it is *not* recommended to insert too many wires into the connector-block ports all these items can be (and usually are already) connected together at another point and a single wire leading from that point can be terminated into the right hand port of the connector-block. Failure to ground any shielding will result in unwanted noise. Please refer to the Harness Diagnostics sheet in Faults & Solutions in this section to diagnose your noise/shielding issues.

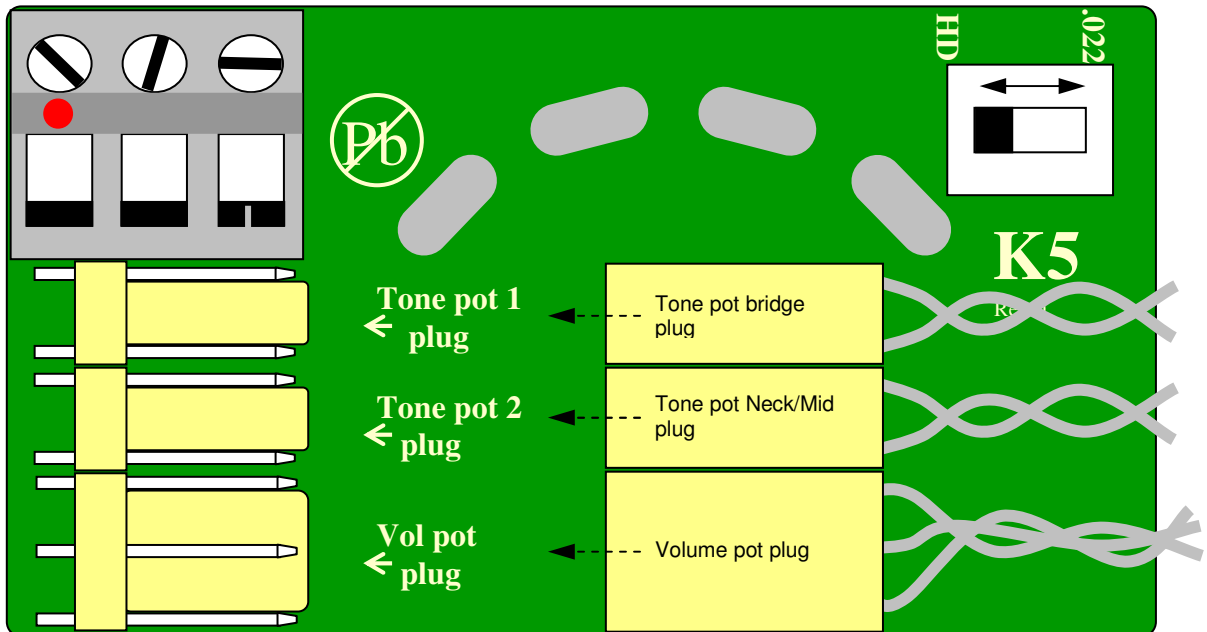
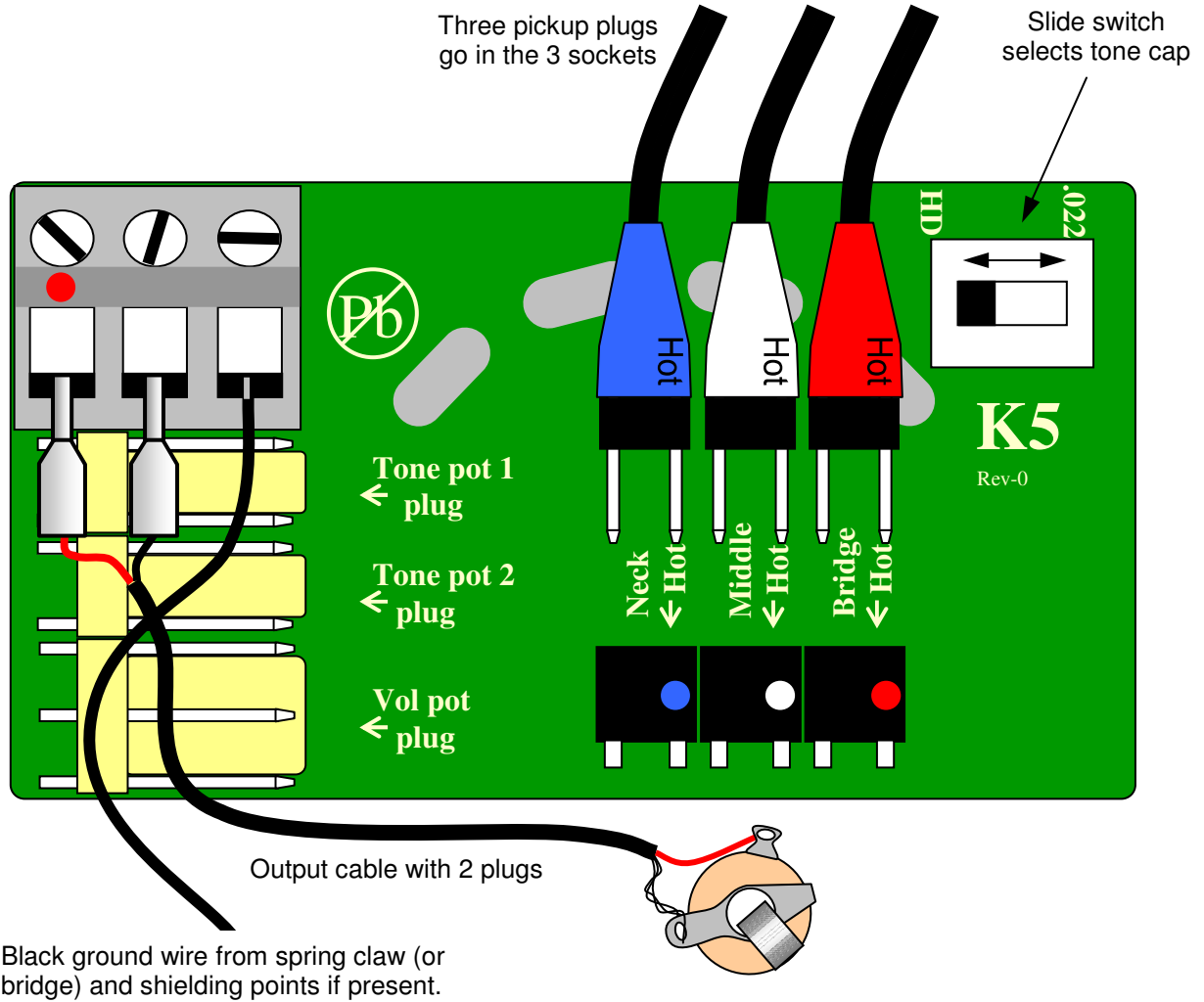

- 13) Assemble the pickguard to body taking care not to cross thread the screws in the wood, and proceed to restring and adjust the pickup heights..... Please visit www.kinman.com >Tech support >Adjust & set-up for detailed info on how to get the best out of your pickups and guitar. There is a wealth of information in this section of my Website that will fascinate and delight you for many hours.

